

Preliminary Data

CMOS IC

Typ	Ordering Code	Package
SLB 0586	Q67100-H8605	P-DIP-8

The IC SLB 0586, constructed in CMOS technology, permits the design of a digital, electronic dimmer. Turning on and off as well as the setting of the required brightness are carried out via a single sensor or via an equivalent extension input, respectively. (The SLB 0586 replaces the S 576 A/B/C family of types).

Features

- Sensor operation – no mechanically moveable switching elements.
- Operation is also possible from several extensions by means of sensors or push-buttons.
- Can be interchanged with electromechanic wall switches in conventional light installations.
- Brightness control with a physiologically approximated linear characteristic.
- Very high interference immunity, also from ripple-control signals.
- Very few peripheral components.
- Programming input for optionally determining 3 dimmer versions (type A/B/C).
- "Soft start" with type A and C.

Pin Configuration

(top view)

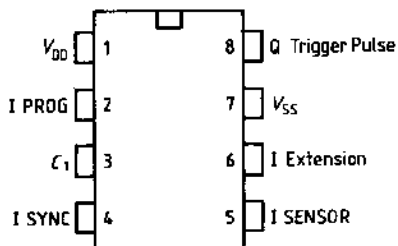
**Pin Description**

Pin	Symbol	Function
1	V_{DD}	Reference point (0 V)
2	I PROG	Programming input
3	C_1	Integrator
4	I SYNC	Sync input
5	I SENSOR	Sensor input
6	I EXTENSION	Extension input
7	V_{SS}	Supply voltage
8	Q trigger pulse	Output trigger pulse

Figure 1
Block Diagram

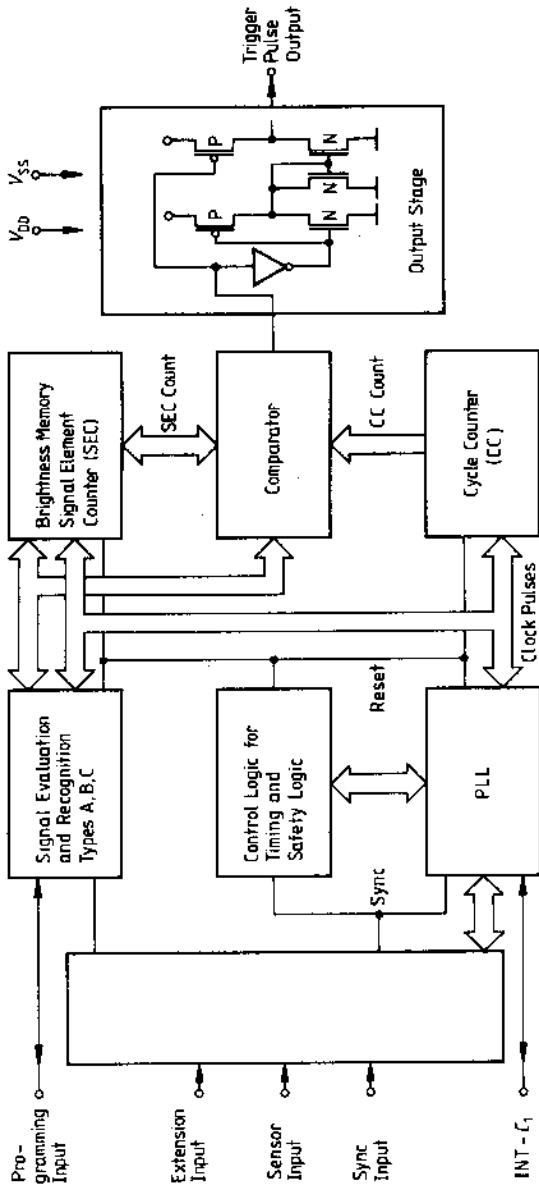

Functional Description

The SLB 0586 permits the design of fully electronic dimmers for light bulbs (resistive loads) which are operated in each case via a single sensor.

In conventional lighting circuit installations it is possible to interchange this component with mechanic wall switches as well as to operate all functions from several switching points (extensions).

The brightness is set by phase control. Its digital logic is synchronized with the line frequency (see block diagram, figure 1).

It is possible to supply the IC via a two-wire-connection as the conduction angle is limited to a maximum of 152° of the half-wave.

Operation (see figure 2)

The integrated circuit can distinguish the instructions "turning ON/OFF" and "dimming" due to the duration of the control input operation.

Turning ON/OFF

Short touch (50 to 400 ms) of the sensor area turns the lamp on or off, depending on its preceding state. The switching process is activated at the end of touching.

Setting of the Brightness (Dimming)

If the sensor is touched for a longer period (> 400 ms), the conduction angle will be varied continuously. It runs across its control loop in 7.6 s (e.g. bright-dark-bright) and continues this sequence until the finger is removed from the sensor.

The following process is carried out to enable an easy operation also in the lower brightness range: the phase control angle is controlled such that during the run across the control loops the lamp brightness varies approximately physiological-linearly with the operating time, and rests for a short period when a minimum brightness is reached.

The conduction angle can be controlled in the half-wave range between 45° and 152° by means of the sync input circuitry (R_2 , C_4) specified in the application example.

Control Behavior

The three dimmer versions A, B and C differ in their control behavior. Depending on the required function, the version is determined via the programming input (see characteristics).

Type A With turning on, the maximum brightness is always set; with dimming, control is started from the minimum brightness. With repeated dimming, control is carried out in the same direction (e.g. "brighter").

Type B With turning off, the selected brightness is stored and again set when the switch is turned on. Dimming starts at that stored value and the control direction is reversed with repeated dimming.

Type C With turning on, the maximum brightness is always set; with dimming, control is started from the minimum brightness. The control direction is reversed with repeated dimming.

Programming of the Different Versions

Type A: $V_{I2} = V_{SS}$ (L)

Type B: $V_{I2} = \text{open}$ (tristate)

Type C: $V_{I2} = V_{DD}$ (H)

V_{I2} = Level at pin 2

Maximum Ratings $V_{DD} = 0$ V (without external protective circuitry)

Description	Symbol	min	max	Unit
Supply voltage	V_{SS}	-7.5	0.3	V
Input voltage	V_I	$V_{SS}-3$	0.3	V
Junction temperature	T_J		125	°C
Storage temperature	T_{stg}	-55	125	°C
Total power dissipation $T_A = 25^\circ\text{C}$			10	mW
Thermal resistance system - air	$R_{th SA}$		135	K/W

Operating Range

Description	Symbol	min	max	Unit
Supply voltage	V_{SS}	-4.8	-5.8	V
Ambient temperature	T_A	0	80	°C

Characteristics $T_A = 25^\circ\text{C}$, $V_{SS} = -5$ V ($V_{DD} = 0$ V)

Description	Symbol	Test conditions	min	typ	max	Unit
Supply current	I_{SS}	$f_{SYNC} = 50/60$ Hz		0.45/0.46	0.6	mA
Supply current with missing sync signal	I_{SS}	$f_{SYNC} = 0$			0.45	mA
Input reverse current	I_I	$V_I = 0$ V		0.5		nA
Input capacitance	C_I	$f = 1$ MHz		5		pF

Sensor Input (Pin 5)

Description	Symbol	Test conditions	min	typ	max	Unit
H input voltage	V_{IH}	with series resistor 10 M Ω from 220 V line	$1/2 V_{SS}+1.1$	33	$1/2 V_{SS}-1.1$	V
L input voltage	V_{IL}					V
Peak input current	I_{IH}					μA
HL transition time (trigger transition)	t_{THL}			line sine wave		
LH transition time	t_{TLH}					
Frequency with active signal	f	synchronized with 50/60 Hz clock at sync input		50/60		Hz

Extension Input (Pin 6)

Description	Symbol	Test conditions	min	typ	max	Unit
H input voltage	V_{IH}		$1/2 V_{SS}+1.1$	0.5	$1/2 V_{SS}-1.1$	V
L input voltage	V_{IL}					V
Input current	I_{IH}	$V_{SS}-0.3$ V (or $V_{DD}+0.3$ V)				μA

Characteristics $T_A = 25^\circ\text{C}$, $V_{SS} = -5\text{ V}$ ($V_{DD} = 0\text{ V}$)

Description	Symbol	Test conditions	min	typ	max	Unit
-------------	--------	-----------------	-----	-----	-----	------

Sync Input (Pin 4)

H input voltage	V_{IH}	with series resistor 1.5 M Ω from 220 V line and diode to V_{DD}	1/2 $V_{SS}+1.1$	207	1/2 $V_{SS}-1.1$	V
L input voltage	V_{IL}					V
Input current	$-I_{IH}$					μA
Input current	I_{IH}					μA
HL transition time (trigger transition)	t_{THL}					line sine wave
LH transition time	t_{TLH}					50/60
Frequency	f					Hz

Programming Input (Pin 2)

Input capacitance to V_{SS}	C_I			7		pF
Load capacitance through PCB with tristate Programming of different versions (see page 342)	C				7	pF

Integrator (Pin 3)

Application circuit	C_5 R_{10}	compare with fig. 3	68 82	100 100	330 120	nF k Ω
---------------------	-------------------	---------------------	----------	------------	------------	------------------

Output (Pin 8)

L output current	I_O	$V_{SS} = -5\text{ V}$ $V_{OL} = -3\text{ V}$	25			mA
L pulse width	t_{QL}	50 Hz line 60 Hz line			39.0 32.6	μs μs
L output voltage	V_L			$V_{DD}-0.6$		V
HL transition time	t_{HLQ}				20	μs
LH transition time	t_{LHQ}				20	μs

Figure 2
Control Behavior of the Different Versions
 (schematic)

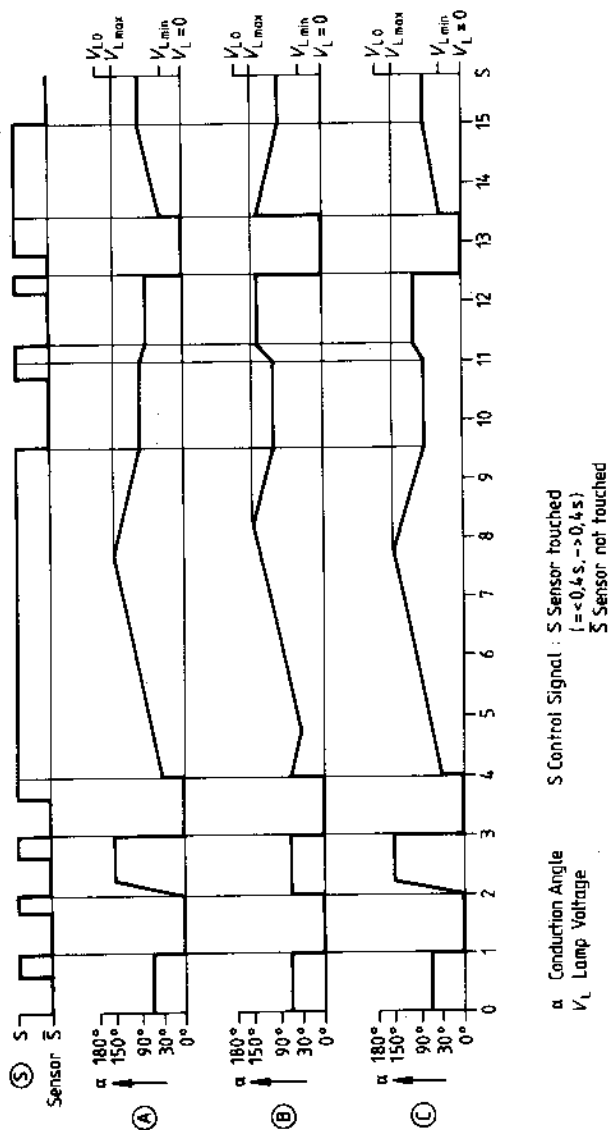

Description of the Application Circuit (see Figure 3)

The suggested circuit design of SLB 0586 performs the following functions

- Current supply for the circuit (R_1 , C_2 , D1, D2, C_3).
- Filtered signal for synchronization of the internal time base (PLL circuit) with line frequency (R_2 , C_4).

For specific applications C_4 can be increased up to 15 nF, however, only at the expense of the lamp brightness so that the lamp gets darker (control range shifts to the left).

- Integration unit for internal PLL circuit (C_5 , R_{10}).
- Protection of the user (R_8 , R_9)
- Sensitivity setting of the sensor (R_7)
- Current limitation in the case of reverse polarity of the extension (R_5 , R_6)

Both resistors can be omitted if no extension is connected. In this case, pin 6 must be interconnected with V_{SS} (pin 7).

- D3: reduction of positive voltages which may arise during the triggered state at the gate of some triacs, to values below $V_{DD}+0.3$ V (refer to maximum ratings). If suitable triacs are used, diode D3 can be omitted. (This feature of the triac depends on the anode current and on the internal resistance between G and A1, and can be measured and specified by the manufacturer).
- Dr: The choke and the capacitor C_1 are used for EMI suppression.

Depending on the application, the EMI suppression is to be dimensioned in acc. with

VDE 0875/part 1 (general)

VDE 0550/part 6 (chokes)

or corresponding to national regulations

e.g. 1.4...2 mH, Q = 11...24.

Figure 4
Application Circuit: Electronic Extension

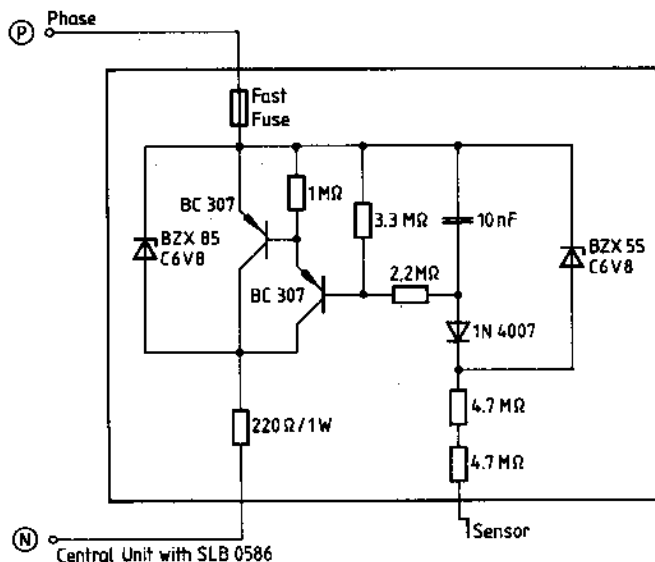

Wireless Remote Control

The connection of a wireless remote control to the extension is very easy. All functions of the SLB 0586 can be performed with the aid of a single transmission channel.

Interference Immunity

A digitally determined immunity period of approximately 50 ms ensures a high interference immunity against electrical variations on the control inputs, and additionally allows an almost delay-free operation.

Due to the special logic of the extension input, even large ground capacitances of the control line will not lead to interference.

In the case of short line interruption, the set switching state with the recommended external circuitry remains stored. After line interruptions for longer periods the circuit turns into the OFF-state.

The control characteristic of the line-synchronous oscillator (PLL circuit) is designed such that interference by ripple-control signals cause only slight changes in brightness. This does not cause a malfunction of the dimmer.

General Information

All stated time specifications refer to a line frequency of 50 Hz. In the case of a line frequency of 60 Hz, the periods are shortened accordingly.

Extensions

All switching and control functions can also be performed from extensions which are connected to an extension input reserved for this purpose. The central unit and the extensions are equivalent. Electronic sensor switches or mechanical pushbutton switches can be connected to the extensions. During operation, H potential must be applied to the extension input for both line half-waves.

An electronic circuit suitable for this purpose, is shown in the application example (figure 4). The circuit operates as return delay and takes over the triggering of the switching transistors during the negative line half-wave.

- Response time approx. 2 ms
- Return delay time approx. 30 ms
- Protection against reverse polarity (R₁, D 1, Si)

Note

The extension input should be switched to V_{SS} , if the input is not used.

Operation of Control Inputs

Input potential during both the half-waves of the line phase

Function	Line half-wave	Sensor input	Extension input		
operated	positive	L	H		
	negative	0	H		
not operated	positive	H	L	or	0
	negative	0	0		L